

PSC- Tooling System

PSC- Werkzeuge



ZCC Cutting Tools Europe GmbH

your Partner | your Value

External Turning Tool Holder / Außendrehhalter

D-Holder · D-Halter

DWLNR/L Kr=95°

- Left hand style shown unless otherwise stated
- Linker Drehhalter gezeigt sofern nicht anders angegeben

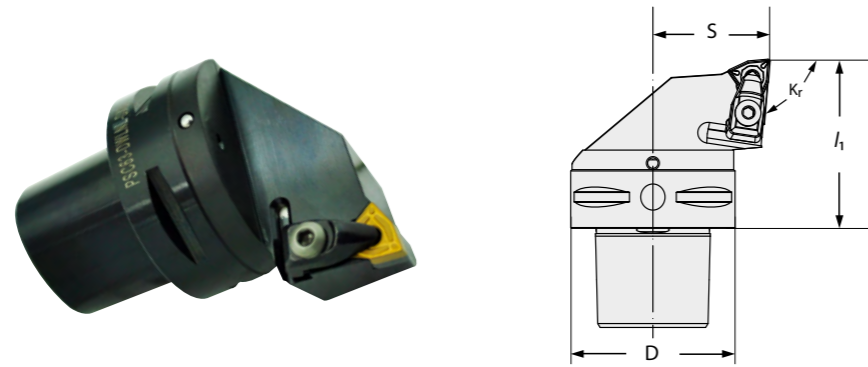

Part number / Bestell-Nr.	Stock / Lager	Dimensions [mm] / Abmessungen [mm]			Insert / WSP
		D	I ₁	S	
PSC40DWLNR2705008	○	40	50	27	WN..0804..
PSC40DWLNL2705008	○	40	50	27	WN..0804..
PSC50DWLNR3506008	○	50	60	35	WN..0804..
PSC50DWLNL3506008	○	50	60	35	WN..0804..
PSC63DWLNR4506508	○	63	65	45	WN..0804..
PSC63DWLNL4506508	○	63	65	45	WN..0804..
PSC80DWLNR5508008	○	80	80	55	WN..0804..
PSC80DWLNL5508008	○	80	80	55	WN..0804..

Spare Parts / Ersatzteile

Part number / Bestell-Nr.	Screw for clamp / Schraube für Pratze	Shim / Unterlage	Wrench / Schlüssel	Clamp / Pratze	Screw for shim / Schraube für Unterlage	Spring / Feder
	CM6x25C	W08BM	WH40L	C2RA	SM6x10XA1	SPR4

● Ex Stock / ab Lager ○ On demand / auf Anfrage

DTJNR/L Kr=93°

- Left hand style shown unless otherwise stated
- Linker Drehhalter gezeigt sofern nicht anders angegeben

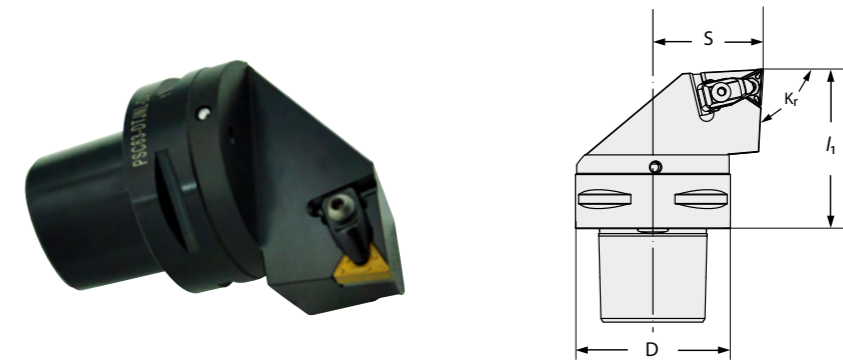

Part number / Bestell-Nr.	Stock / Lager	Dimensions [mm] / Abmessungen [mm]			Insert / WSP
		D	I ₁	S	
PSC32DTJNR2204016	○	32	40	22	TN..1604..
PSC32DTJNL2204016	○	32	40	22	TN..1604..
PSC40DTJNR2705016	○	40	50	27	TN..1604..
PSC40DTJNL2705016	○	40	50	27	TN..1604..
PSC50DTJNR3506016	○	50	60	35	TN..1604..
PSC50DTJNL3506016	○	50	60	35	TN..1604..
PSC63DTJNR4506516	○	63	65	45	TN..1604..
PSC63DTJNL4506516	○	63	65	45	TN..1604..

Spare Parts / Ersatzteile

Part number / Bestell-Nr.	Screw for clamp / Schraube für Pratze	Shim / Unterlage	Wrench / Schlüssel	Clamp / Pratze	Screw for shim / Schraube für Unterlage	Spring / Feder
	CM5x22C	T16BM	WH30L	C1RA	SM5x8.65XA1	SPR6

● Ex Stock / ab Lager ○ On demand / auf Anfrage

DCLNR/L Kr=95°

- Right hand style shown unless otherwise stated
- Rechter Drehhalter gezeigt sofern nicht anders angegeben

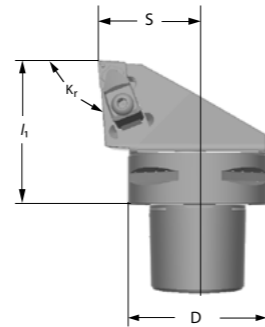
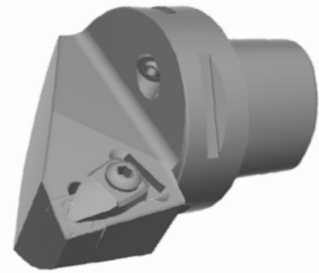

Part number / Bestell-Nr.	Stock / Lager	Dimensions [mm] / Abmessungen [mm]			Insert / WSP
		D	I ₁	S	
PSC32DCLNR2204512	○	32	45	22	CN..1204..
PSC32DCLNL2204512	○	32	45	22	CN..1204..
PSC40DCLNR2705012	○	40	50	27	CN..1204..
PSC40DCLNL2705012	○	40	50	27	CN..1204..
PSC50DCLNR3506012	●	50	60	35	CN..1204..
PSC50DCLNL3506012	○	50	60	35	CN..1204..
PSC63DCLNR4506512	●	63	65	45	CN..1204..
PSC63DCLNL4506512	●	63	65	45	CN..1204..
PSC80DCLNR5508012	○	80	80	55	CN..1204..
PSC80DCLNL5508012	○	80	80	55	CN..1204..

Spare Parts / Ersatzteile

Part number / Bestell-Nr.	Screw for clamp / Schraube für Pratze	Shim / Unterlage	Wrench / Schlüssel	Clamp / Pratze	Screw for shim / Schraube für Unterlage	Spring / Feder
	CM6x25C	C12BM	WH40L	C2RA	SM6x10XA1	SPR4

● Ex Stock / ab Lager ○ On demand / auf Anfrage

DDJNR/L Kr=93°

- Left hand style shown unless otherwise stated
- Linker Drehhalter gezeigt sofern nicht anders angegeben

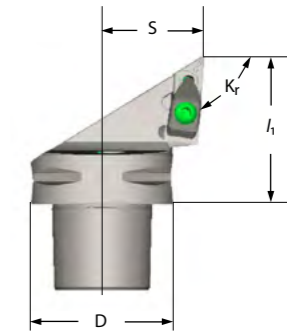
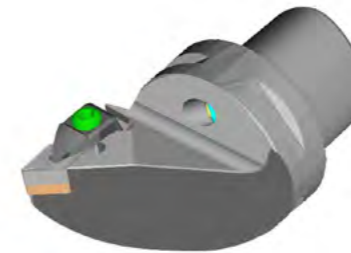

Part number / Bestell-Nr.	Stock / Lager	Dimensions [mm] / Abmessungen [mm]			Insert / WSP
		D	I ₁	S	
PSC32DDJNR2204511	○	32	45	22	DN..1104..
PSC32DDJNL2204511	○	32	45	22	DN..1104..
PSC40DDJNR2705011	○	40	50	27	DN..1104..
PSC40DDJNL2705011	○	40	50	27	DN..1104..
PSC50DDJNR3506011	○	50	60	35	DN..1104..
PSC50DDJNL3506011	○	50	60	35	DN..1104..
PSC63DDJNR4506511	○	63	65	45	DN..1104..
PSC63DDJNL4506511	○	63	65	45	DN..1104..

Spare Parts / Ersatzteile

Part number / Bestell-Nr.	Screw for clamp / Schraube für Pratze	Shim / Unterlage	Wrench / Schlüssel	Clamp / Pratze	Screw for shim / Schraube für Unterlage	Spring / Feder
	CM5x22C	D11BM	WH30L	C1RA	SM5x8.65XA1	SPR6

Part number / Bestell-Nr.	Stock / Lager	Dimensions [mm] / Abmessungen [mm]			Insert / WSP
		D	I ₁	S	
PSC40DDJNR2705515	○	40	55	27	DN..1506..
PSC40DDJNL2705515	○	40	55	27	DN..1506..
PSC50DDJNR3506015	●	50	60	35	DN..1506..
PSC50DDJNL3506015	●	50	60	35	DN..1506..
PSC63DDJNR4506515	●	63	65	45	DN..1506..
PSC63DDJNL4506515	●	63	65	45	DN..1506..

Spare Parts / Ersatzteile

Part number / Bestell-Nr.	Screw for clamp / Schraube für Pratze	Shim / Unterlage	Wrench / Schlüssel	Clamp / Pratze	Screw for shim / Schraube für Unterlage	Spring / Feder
	CM6x22C	D15BM	WH40L	C2RA	SM6x10XA1	SPR4

● Ex Stock / ab Lager ○ On demand / auf Anfrage

P-Holder · P-Halter

PCLNR/L Kr=95°

- Right hand style shown unless otherwise stated
- Rechter Drehhalter gezeigt sofern nicht anders angegeben

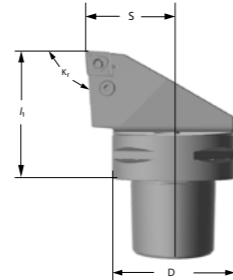

Part number / Bestell-Nr.	Stock / Lager	Dimensions [mm] / Abmessungen [mm]			Insert / WSP
		D	I ₁	S	
PSC32PCLNR2204012	○	32	40	22	CN..1204..
PSC32PCLNL2204012	○	32	40	22	CN..1204..
PSC40PCLNR2705012	○	40	50	27	CN..1204..
PSC40PCLNL2705012	●	40	50	27	CN..1204..
PSC50PCLNR3506012	●	50	60	35	CN..1204..
PSC50PCLNL3506012	●	50	60	35	CN..1204..
PSC63PCLNR4506512	●	63	65	45	CN..1204..
PSC63PCLNL4506512	●	63	65	45	CN..1204..
PSC80PCLNR5508012	○	80	80	55	CN..1204..
PSC80PCLNL5508012	○	80	80	55	CN..1204..

Spare Parts / Ersatzteile

Part number / Bestell-Nr.	Screw / Schraube	Shim / Unterlage	Wrench / Schlüssel	Lever / Kniehebel	Shim Pin / Rohrstift
	LEM8x21	C12AP	WH30L	L4	SP4

Part number / Bestell-Nr.	Stock / Lager	Dimensions [mm] / Abmessungen [mm]			Insert / WSP
		D	I ₁	S	
PSC40PCLNR2705016	○	40	50	27	CN..1606..
PSC40PCLNL2705016	○	40	50	27	CN..1606..
PSC50PCLNR3506016	●	50	60	35	CN..1606..
PSC50PCLNL3506016	●	50	60	35	CN..1606..
PSC63PCLNR4506516	●	63	65	45	CN..1606..
PSC63PCLNL4506516	●	63	65	45	CN..1606..
PSC80PCLNR5508016	●	80	80	55	CN..1606..
PSC80PCLNL5508016	●	80	80	55	CN..1606..

Spare Parts / Ersatzteile

Part number / Bestell-Nr.	Screw / Schraube	Shim / Unterlage	Wrench / Schlüssel	Lever / Kniehebel	Shim Pin / Rohrstift
	LEM8x25	C16AP	WH30L	L5	SP5

Part number / Bestell-Nr.	Stock / Lager	Dimensions [mm] / Abmessungen [mm]			Insert / WSP
		D	I ₁	S	
PSC50PCLNR3506019	●	50	60	35	CN..1906..
PSC50PCLNL3506019	●	50	60	35	CN..1906..
PSC63PCLNR4506519	●	63	65	45	CN..1906..
PSC63PCLNL4506519	●	63	65	45	CN..1906..
PSC80PCLNR5508019	●	80	80	55	CN..1906..
PSC80PCLNL5508019	●	80	80	55	CN..1906..

Spare Parts / Ersatzteile

Part number / Bestell-Nr.	Screw / Schraube	Shim / Unterlage	Wrench / Schlüssel	Lever / Kniehebel	Shim Pin / Rohrstift
	LEM10x27	C19AP	WH40L	L6	SP6

PCRRN/L Kr=75°

- Left hand style shown unless otherwise stated
- Linker Drehhalter gezeigt sofern nicht anders angegeben

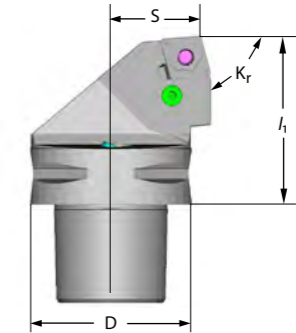
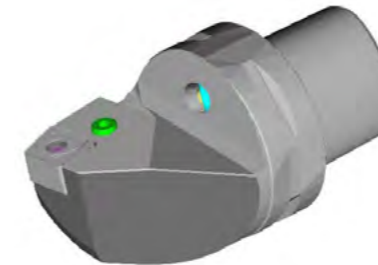

Part number / Bestell-Nr.	Stock / Lager	Dimensions [mm] / Abmessungen [mm]			Insert / WSP
		D	I ₁	S	
PSC50PCRRN2706012	●	50	60	27	CN..1204..
PSC50PCRRNL2706012	●	50	60	27	CN..1204..
PSC63PCRRN3506512	●	63	65	35	CN..1204..
PSC63PCRRNL3506512	●	63	65	35	CN..1204..

Spare Parts / Ersatzteile

Part number / Bestell-Nr.	Screw / Schraube	Shim / Unterlage	Wrench / Schlüssel	Lever / Kniehebel	Shim Pin / Rohrstift
	LEM8x21	C12AP	WH30L	L4	SP4

Part number / Bestell-Nr.	Stock / Lager	Dimensions [mm] / Abmessungen [mm]			Insert / WSP
		D	I ₁	S	
PSC50PCRRN2706016	●	50	60	27	CN..1606..
PSC50PCRRNL2706016	●	50	60	27	CN..1606..
PSC63PCRRN3506516	●	63	65	35	CN..1606..
PSC63PCRRNL3506516	●	63	65	35	CN..1606..

Spare Parts / Ersatzteile

Part number / Bestell-Nr.	Screw / Schraube	Shim / Unterlage	Wrench / Schlüssel	Lever / Kniehebel	Shim Pin / Rohrstift
	LEM8x25	C16AP	WH30L	L5	SP5

Part number / Bestell-Nr.	Stock / Lager	Dimensions [mm] / Abmessungen [mm]			Insert / WSP
		D	I ₁	S	
PSC50PCRRN2706019	●	50	60	27	CN..1606..
PSC50PCRRNL2706019	●	50	60	27	CN..1606..
PSC63PCRRN3506519	●	63	65	35	CN..1606..
PSC63PCRRNL3506519	●	63	65	35	CN..1606..

Spare Parts / Ersatzteile

Part number / Bestell-Nr.	Screw / Schraube	Shim / Unterlage	Wrench / Schlüssel	Lever / Kniehebel	Shim Pin / Rohrstift
	LEM10x27	C19AP	WH40L	L6	SP6

PDJNR/L Kr=93°

- Left hand style shown unless otherwise stated
- Linker Drehhalter gezeigt sofern nicht anders angegeben

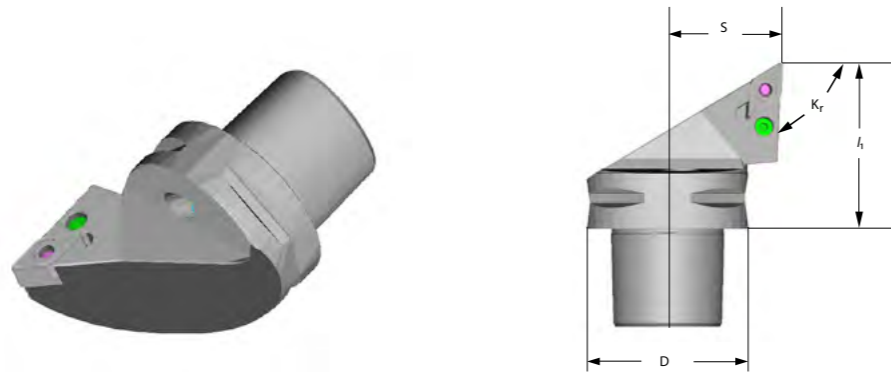

Part number / Bestell-Nr.	Stock / Lager	Dimensions [mm] / Abmessungen [mm]			Insert / WSP
		D	I ₁	S	
PSC40PDJNR2705015	○	40	50	27	DN..1506..
PSC40PDJNL2705015	○	40	50	27	DN..1506..
PSC50PDJNR3506015	●	50	60	35	DN..1506..
PSC50PDJNL3506015	●	50	60	35	DN..1506..
PSC63PDJNR4506515	○	63	65	45	DN..1506..
PSC63PDJNL4506515	○	63	65	45	DN..1506..

Spare Parts / Ersatzteile

Part number / Bestell-Nr.	Screw / Schraube	Shim / Unterlage	Wrench / Schlüssel	Lever / Kniehebel	Shim Pin / Rohrstift
	LEM8x21	D15AP	WH30L	L4B	SP4

● Ex Stock / ab Lager ○ On demand / auf Anfrage

S-Holder · S-Halter

SCLCR/L Kr=95°

- Left hand style shown unless otherwise stated
- Linker Drehhalter gezeigt sofern nicht anders angegeben



Part number / Bestell-Nr.	Stock / Lager	Dimensions [mm] / Abmessungen [mm]			Insert / WSP
		D	I ₁	S	
PSC32SCLCR2204009	○	32	40	22	CC..09T3..
PSC32SCLCL2204009	○	32	40	22	CC..09T3..
PSC40SCLCR2705009	○	40	50	27	CC..09T3..
PSC40SCLCL2705009	○	40	50	27	CC..09T3..
PSC50SCLCR3506009	○	50	60	35	CC..09T3..
PSC50SCLCL3506009	○	50	60	35	CC..09T3..
PSC63SCLCR4506509	○	63	65	45	CC..09T3..
PSC63SCLCL4506509	○	63	65	45	CC..09T3..

Spare Parts / Ersatzteile

Part number / Bestell-Nr.	Screw / Schraube	Wrench for Screw / Schlüssel für Schraube	Shim / Unterlage	Screw for shim / Schraube für Unterlage	Wrench for shim screw / Schlüssel für Unterlageschraube
	I60M3.5x8	WT15IP	-	-	-

Part number / Bestell-Nr.	Stock / Lager	Dimensions [mm] / Abmessungen [mm]			Insert / WSP
		D	I ₁	S	
PSC32SCLCR2204012	○	32	40	22	CC..1204..
PSC32SCLCL2204012	○	32	40	22	CC..1204..
PSC40SCLCR2705012	○	40	50	27	CC..1204..
PSC40SCLCL2705012	○	40	50	27	CC..1204..
PSC50SCLCR3506012	●	50	60	35	CC..1204..
PSC50SCLCL3506012	●	50	60	35	CC..1204..
PSC63SCLCR4506512	●	63	65	45	CC..1204..
PSC63SCLCL4506512	●	63	65	45	CC..1204..

Spare Parts / Ersatzteile

Part number / Bestell-Nr.	Screw / Schraube	Wrench for Screw / Schlüssel für Schraube	Shim / Unterlage	Screw for shim / Schraube für Unterlage	Wrench for shim screw / Schlüssel für Unterlageschraube
	I60M4x11X	WT15IP	C12BS	SM6*10XA	WH40L

● Ex Stock / ab Lager ○ On demand / auf Anfrage

SDJCR/L Kr=93°

- Left hand style shown unless otherwise stated
- Linker Drehhalter gezeigt sofern nicht anders angegeben

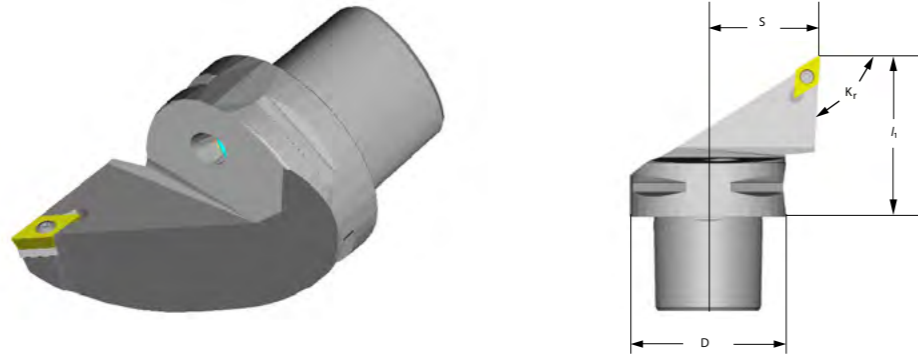

Part number / Bestell-Nr.	Stock / Lager	Dimensions [mm] / Abmessungen [mm]			Insert / WSP
		D	I ₁	S	
PSC40SDJCR2705011	○	40	50	27	DC..11T3..
PSC40SDJCL2705011	○	40	50	27	DC..11T3..
PSC50SDJCR3506011	●	50	60	35	DC..11T3..
PSC50SDJCL3506011	●	50	60	35	DC..11T3..
PSC63SDJCR4506511	●	63	65	45	DC..11T3..
PSC63SDJCL4506511	●	63	65	45	DC..11T3..

Spare Parts / Ersatzteile

Part number / Bestell-Nr.	Screw / Schraube	Wrench for Screw / Schlüssel für Schraube	Shim / Unterlage	Screw for shim / Schraube für Unterlage	Wrench for shim screw / Schlüssel für Unterlageschraube
	I60M3.5x12	WT15IP	D11BS	SM5x8.65XA	WH35L

● Ex Stock / ab Lager ○ On demand / auf Anfrage

SVJBR/L Kr=93°

- Right hand style shown unless otherwise stated
- Rechter Drehhalter gezeigt sofern nicht anders angegeben

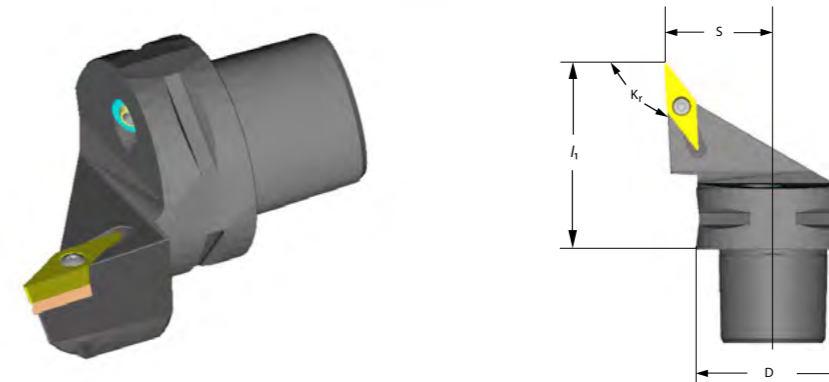

Part number / Bestell-Nr.	Stock / Lager	Dimensions [mm] / Abmessungen [mm]			Insert / WSP
		D	I ₁	S	
PSC40SVJBR2705016	○	40	50	27	VB..1604..
PSC40SVJBL2705016	○	40	50	27	VB..1604..
PSC50SVJBR3506016	●	50	60	35	VB..1604..
PSC50SVJBL3506016	●	50	60	35	VB..1604..
PSC63SVJBR4506516	●	63	65	45	VB..1604..
PSC63SVJBL4506516	●	63	65	45	VB..1604..

Spare Parts / Ersatzteile

Part number / Bestell-Nr.	Screw / Schraube	Wrench for Screw / Schlüssel für Schraube	Shim / Unterlage	Screw for shim / Schraube für Unterlage	Wrench for shim screw / Schlüssel für Unterlageschraube
	I60M3.5x12	WT15IP	V16BS	SM5x8.65XA	WH35L

● Ex Stock / ab Lager ○ On demand / auf Anfrage

Internal Turning Tool Holder / Innendrehhalter

P-Holder · P-Halter

PCLNR/L Kr=95°

- Right hand style shown unless otherwise stated
- Rechter Drehhalter gezeigt sofern nicht anders angegeben

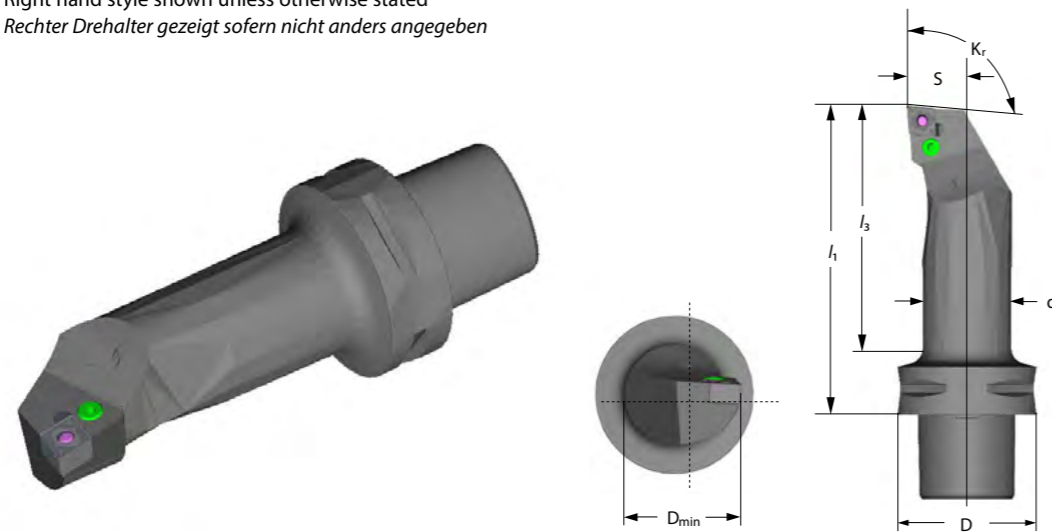

Part number / Bestell-Nr.	Stock / Lager	Dimensions [mm] / Abmessungen [mm]						Insert / WSP
		D	d	Dmin	l ₁	l ₃	S	
PSC40PCLNR1709012	○	40	25	32	90	69	17	CN..1204..
PSC40PCLNL1709012	○	40	25	32	90	69	17	CN..1204..
PSC50PCLNR2211012	●	50	32	40	110	89	22	CN..1204..
PSC50PCLNL2211012	●	50	32	40	110	89	22	CN..1204..
PSC63PCLNR2714012	●	63	40	50	140	118	27	CN..1204..
PSC63PCLNL2714012	●	63	40	50	140	118	27	CN..1204..

Spare Parts / Ersatzteile

Part number / Bestell-Nr.	Screw / Schraube	Shim / Unterlage	Wrench / Schlüssel	Lever / Kniehebel	Shim Pin / Rohrstift
	LEM8x21	C12AP	WH30L	L4	SP4

● Ex Stock / ab Lager ○ On demand / auf Anfrage

PDQNR/L Kr=107,5°

- Right hand style shown unless otherwise stated
- Rechter Drehhalter gezeigt sofern nicht anders angegeben



Part number / Bestell-Nr.	Stock / Lager	Dimensions [mm] / Abmessungen [mm]						Insert / WSP
		D	d	Dmin	l ₁	l ₃	S	
PSC50PDQNR2714015	●	63	40	50	140	118	27	DN..1506..
PSC50PDQNL2714015	●	63	40	50	140	118	27	DN..1506..
PSC63PDQNR2211015	●	63	40	50	180	158	27	DN..1506..
PSC63PDQNL2211015	●	63	40	50	180	158	27	DN..1506..

Spare Parts / Ersatzteile

Part number / Bestell-Nr.	Screw / Schraube	Shim / Unterlage	Wrench / Schlüssel	Lever / Kniehebel	Shim Pin / Rohrstift
	LEM8x21	D15AP	WH30L	L4B	SP4

● Ex Stock / ab Lager ○ On demand / auf Anfrage

S-Holder · S-Halter

SCLCR/L Kr=95°

- Right hand style shown unless otherwise stated
- Rechter Drehhalter gezeigt sofern nicht anders angegeben

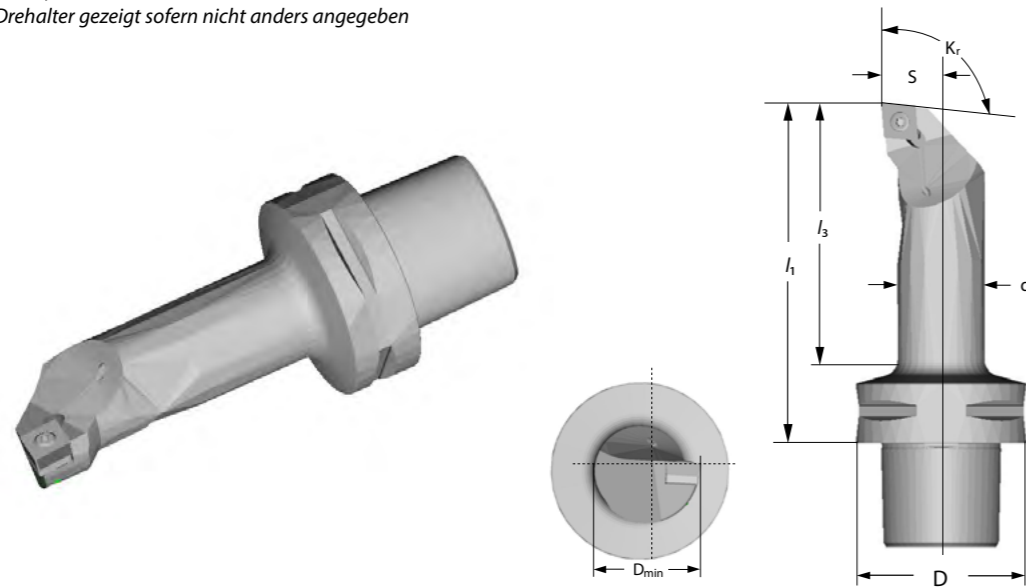

Part number / Bestell-Nr.	Stock / Lager	Dimensions [mm] / Abmessungen [mm]						Insert / WSP
		D	d	Dmin	l ₁	l ₃	S	
PSC40SCLCR1709012	○	40	25	32	90	69	17	CC..1204..
PSC40SCLCL1709012	○	40	25	32	90	69	17	CC..1204..
PSC40SCLCR2211012	○	40	32	40	110	89	22	CC..1204..
PSC40SCLCL2211012	○	40	32	40	110	89	22	CC..1204..
PSC50SCLCR2211012	●	50	32	40	110	88	22	CC..1204..
PSC50SCLCL2211012	●	50	32	40	110	88	22	CC..1204..
PSC63SCLCR2212512	●	63	32	40	125	103	22	CC..1204..
PSC63SCLCL2212512	●	63	32	40	125	103	22	CC..1204..
PSC63SCLCR2714012	●	63	40	50	140	118	27	CC..1204..
PSC63SCLCL2714012	●	63	40	50	140	118	27	CC..1204..

Spare Parts / Ersatzteile

Part number / Bestell-Nr.	Screw / Schraube	Wrench for Screw / Schlüssel für Schraube	Shim / Unterlage	Screw for shim / Schraube für Unterlage	Wrench for shim screw / Schlüssel für Unterlageschraube
	I60M4x11X	WT15IP	C12BS	SM6*10XA	WH40L

● Ex Stock / ab Lager ○ On demand / auf Anfrage

SDQCR/L Kr=107,5°

- Right hand style shown unless otherwise stated
- Rechter Drehhalter gezeigt sofern nicht anders angegeben

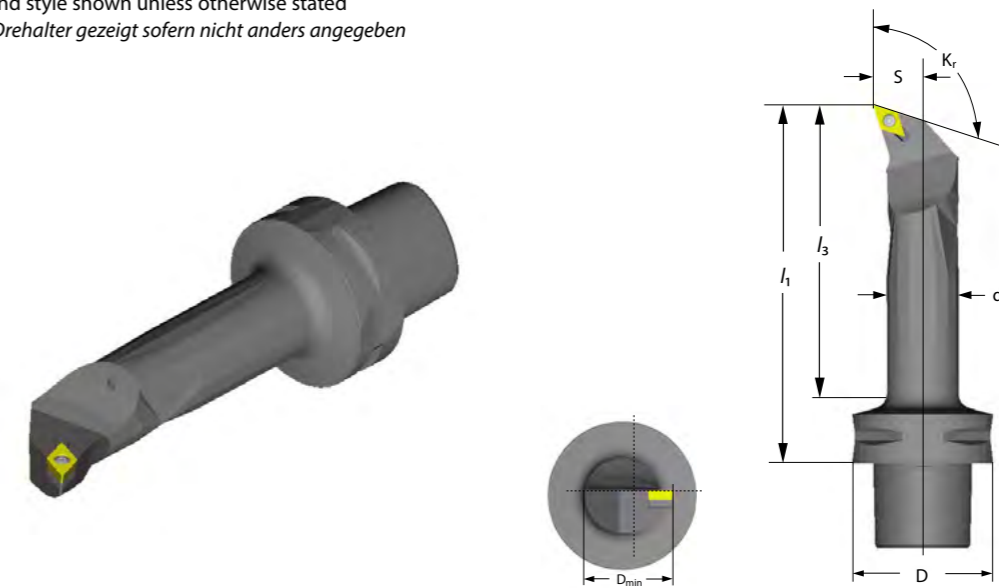

Part number / Bestell-Nr.	Stock / Lager	Dimensions [mm] / Abmessungen [mm]						Insert / WSP
		D	d	Dmin	l ₁	l ₃	S	
PSC40SDQCR1709011	○	40	25	32	90	69	17	DC..11T3..
PSC40SDQCL1709011	○	40	25	32	90	69	17	DC..11T3..
PSC50SDQCR1709011	●	50	25	32	90	67	17	DC..11T3..
PSC50SDQCL1709011	●	50	25	32	90	67	17	DC..11T3..
PSC50SDQCR2211011	●	50	32	40	110	88	22	DC..11T3..
PSC50SDQCL2211011	●	50	32	40	110	88	22	DC..11T3..
PSC63SDQCR2212511	●	63	32	40	125	103	22	DC..11T3..
PSC63SDQCL2212511	●	63	32	40	125	103	22	DC..11T3..
PSC63SDQCR2216011	●	63	32	40	160	138	22	DC..11T3..
PSC63SDQCL2216011	●	63	32	40	160	138	22	DC..11T3..

Spare Parts / Ersatzteile

Part number / Bestell-Nr.	Screw / Schraube	Wrench for Screw / Schlüssel für Schraube	Shim / Unterlage	Screw for shim / Schraube für Unterlage	Wrench for shim screw / Schlüssel für Unterlageschraube
	I60M3.5x12	WT15IP	D11BS	SM5x8.65XA	WH35L

● Ex Stock / ab Lager ○ On demand / auf Anfrage



Vertriebszentrale in Europa
Sales center in Europe

ZCC Cutting Tools Europe GmbH

**Vertretung
Distributor**

Trade Technology

RUSSIA, Moscow, Ordzhonikidze str. 11 build 11

Tel.: +7(499)650-50-31

www.zcc-ct.ru

E-mail: info@zcc-ct.ru

© Copyright by ZCC Cutting Tools Europe GmbH
All rights reserved / Alle Rechte vorbehalten.

All rights reserved. All descriptions and pictures are protected by copyright. Usage, modification and reproduction, completely or partially, without written permission are prohibited. Subject to technical changes and changes of the delivery program. Mistakes and printing errors are reserved.

Alle Rechte vorbehalten. Alle Beschreibungen und Abbildungen sind urheberrechtlich geschützt. Die Verwendung, Modifikation und Vervielfältigung, ganz oder teilweise, ohne schriftliche Genehmigung sind untersagt. Technische Änderungen und Änderungen des Lieferprogrammes vorbehalten. Für Druckfehler und Irrtümer keine Gewähr.